

9. Gas Piping

Follow the instructions from the gas supplier.

The appliance and its individual shutoff valve must be disconnected from the gas supply piping system during any pressure testing of that system at test pressures in excess of 1/2 psig (3.5 kPa).

The Appliance must be isolated from the gas supply piping system by closing its individual manual shutoff valve during any pressure testing of the gas supply piping system at test pressures equal to or less than 1/2 psig (3.5 kPa).

The appliance and its gas connections must be leak tested before placing the appliance in operation.

The inlet gas pressure must be within the range specified. This is for the purposes of input adjustment.

In order to choose the proper size for the gas line, consult local codes or the National Fuel Gas Code ANSI Z223.1.

Gas Pressure

Size the gas line according to total btuh demand of the building and length from the meter or regulator so that the following supply pressures are available even at maximum demand:

Natural Gas Supply Pressure

- Min. 5" WC
- Max. 10.5" WC

LP Gas Supply Pressure

- Min. 10.5" WC
- Max. 14" WC

Gas Meter

Select a gas meter capable of supplying the entire btuh demand of all gas appliances in the building.

Gas Connection

- Do not use piping with a diameter smaller than the inlet diameter of the water heater.
- Gas flex lines are not recommended unless they are rated for 380,000 btuh.
- Install a gas shutoff valve on the supply line.
- Use only approved gas piping materials.

Measuring Gas Pressure

In order to check the gas supply pressure to the unit, a tap is provided on the gas inlet. Remove the hex head philips screw from the tap, and connect a manometer using a silicon tube.

In order to check the gas manifold pressure, a pair of taps are provided on the gas valve inside the unit. The pressure can be checked either by removing the hex head philips screw and connecting a manometer with a silicon tube, or by removing the 1/8" NPT screw with an allen wrench and connecting the appropriate pressure gauge.

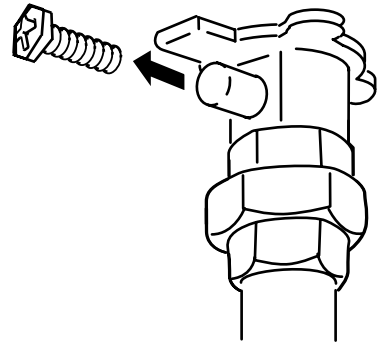

Sample Gas Line

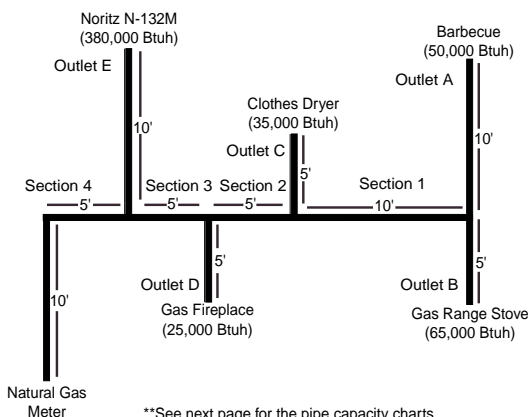

**See next page for the pipe capacity charts.

Instructions

1. Size each outlet branch starting from the furthest using the Btuh required and the length from the meter.
2. Size each section of the main line using the length to the furthest outlet and the Btuh required by everything after that section.

Sample Calculation

- Outlet A: 45' (Use 50'), 50,000 Btuh requires 1/2"
- Outlet B: 40', 65,000 Btuh requires 1/2"
- Section 1: 45' (Use 50'), 115,000 Btuh requires 3/4"
- Outlet C: 30', 35,000 Btuh requires 1/2"
- Section 2: 45' (Use 50'), 150,000 Btuh requires 3/4"
- Outlet D: 25' (Use 30'), 25,000 Btuh requires 1/2"
- Section 3: 45' (Use 50'), 175,000 Btuh requires 1"
- Outlet E: 25' (Use 30'), 380,000 Btuh requires 1 1/4"
- Section 4: 45' (Use 50'), 555,000 Btuh requires 1 1/4"

Gas Line Sizing for a Noritz N-132M

Adapted from UPC 1997

Maximum **Natural Gas** Delivery Capacity in Cubic Feet per Hour (0.60 Specific Gravity, 0.5" WC Pressure Drop)

| Pipe Size | Length in Feet | | | | | | | | | | |
|-----------|----------------|--------|--------|--------|------|------|------|------|------|------|------|
| | 10' | 20' | 30' | 40' | 50' | 60' | 70' | 80' | 90' | 100' | 125' |
| 1/2" | 174 | 119 | 96 | 82 | 73 | 66 | 61 | 56 | 53 | 50 | 44 |
| 3/4" | 363 | 249 | 200 | 171 | 152 | 138 | 127 | 118 | 111 | 104 | 93 |
| 1" | 684 | 470 | 377 | 323 | 286 | 259 | 239 | 222 | 208 | 197 | 174 |
| 1 1/4" | 1404 | 965 | 775 | 663 | 588 | 532 | 490 | 456 | 428 | 404 | 358 |
| 1 1/2" | 2103 | 1445 | 1161 | 993 | 880 | 798 | 734 | 683 | 641 | 605 | 536 |
| 2" | 4050 | 2784 | 2235 | 1913 | 1696 | 1536 | 1413 | 1315 | 1234 | 1165 | 1033 |
| 2 1/2" | 6455 | 4437 | 3563 | 3049 | 2703 | 2449 | 2253 | 2096 | 1966 | 1857 | 1646 |
| 3" | 11,412 | 7843 | 6299 | 5391 | 4778 | 4329 | 3983 | 3705 | 3476 | 3284 | 2910 |
| 3 1/2" | 16,709 | 11,484 | 9222 | 7893 | 6995 | 6338 | 5831 | 5425 | 5090 | 4808 | 4261 |
| 4" | 23,277 | 15,998 | 12,847 | 10,995 | 9745 | 8830 | 8123 | 7557 | 7091 | 6698 | 5936 |

Contact the Gas Supplier for Btu/Cubic Ft. of the Supplied Gas. 1000 BTU/Cubic Ft. is a Typical Value

Maximum **Liquified Petroleum** (Undiluted) Delivery Capacity in Thousands of Btuh (0.5" WC Pressure Drop)

| Pipe Size | Length in Feet | | | | | | | | | | | | |
|-----------|----------------|------|------|------|------|------|------|------|------|------|------|------|------|
| | 10' | 20' | 30' | 40' | 50' | 60' | 70' | 80' | 90' | 100' | 125' | 150' | 200' |
| 1/2" | 275 | 189 | 152 | 129 | 114 | 103 | 96 | 89 | 83 | 78 | 69 | 63 | 55 |
| 3/4" | 567 | 393 | 315 | 267 | 237 | 217 | 196 | 185 | 173 | 162 | 146 | 132 | 112 |
| 1" | 1071 | 732 | 590 | 504 | 448 | 409 | 378 | 346 | 322 | 307 | 275 | 252 | 213 |
| 1 1/4" | 2205 | 1496 | 1212 | 1039 | 913 | 834 | 771 | 724 | 677 | 630 | 567 | 511 | 440 |
| 1 1/2" | 3307 | 2299 | 1858 | 1559 | 1417 | 1275 | 1181 | 1086 | 1023 | 976 | 866 | 787 | 675 |
| 2" | 6221 | 4331 | 3465 | 2992 | 2646 | 2394 | 2205 | 2047 | 1921 | 1811 | 1606 | 1496 | 1260 |

** For reference only. Please consult gas pipe manufacturer for actual pipe capacities.

Maximum Capacity of Flex TracPipe® in Cubic Feet per Hour of **Natural Gas** (0.60 Specific Gravity, 0.5" WC Pressure Drop)

| Pipe Size | Length in Feet | | | | | | | | | | | |
|-----------|----------------|------|------|------|------|------|------|------|-----|------|------|------|
| | 10' | 20' | 30' | 40' | 50' | 60' | 70' | 80' | 90' | 100' | 150' | 200' |
| 3/4" | 206 | 147 | 121 | 105 | 94 | 86 | 80 | 75 | 71 | 67 | 55 | 48 |
| 1" | 383 | 269 | 218 | 188 | 168 | 153 | 141 | 132 | 125 | 118 | 94 | 82 |
| 1 1/4" | 614 | 418 | 334 | 284 | 251 | 227 | 209 | 194 | 181 | 171 | 137 | 116 |
| 1 1/2" | 1261 | 888 | 723 | 625 | 559 | 509 | 471 | 440 | 415 | 393 | 320 | 277 |
| 2" | 2934 | 2078 | 1698 | 1472 | 1317 | 1203 | 1114 | 1042 | 983 | 933 | 762 | 661 |

Maximum Capacity of Flex TracPipe® in Thousands of Btuh **Liquified Petroleum** (0.5" WC Pressure Drop)

| Pipe Size | Length in Feet | | | | | | | | | | | |
|-----------|----------------|------|------|------|------|------|------|------|------|------|------|------|
| | 10' | 20' | 30' | 40' | 50' | 60' | 70' | 80' | 90' | 100' | 150' | 200' |
| 3/4" | 325 | 232 | 191 | 166 | 149 | 136 | 126 | 118 | 112 | 106 | 87 | 76 |
| 1" | 605 | 425 | 344 | 297 | 265 | 241 | 222 | 208 | 197 | 186 | 143 | 129 |
| 1 1/4" | 971 | 661 | 528 | 449 | 397 | 359 | 330 | 307 | 286 | 270 | 217 | 183 |
| 1 1/2" | 1993 | 1404 | 1143 | 988 | 884 | 805 | 745 | 696 | 656 | 621 | 506 | 438 |
| 2" | 4638 | 3285 | 2684 | 2327 | 2082 | 1902 | 1761 | 1647 | 1554 | 1475 | 1205 | 1045 |

** For reference only. Please consult gas pipe manufacturer for actual pipe capacities.

TracPipe® is a registered trademark of Omega Flex.

Maximum Capacity for Gas Flex Connectors in Cubic Feet per Hour of **Natural Gas** (0.60 Specific Gravity, 0.5" WC Pressure Drop)

| Pipe Size | Length in Inches | | | | | |
|-----------|------------------|------|------|------|-----|-----|
| | 12" | 24" | 36" | 48" | 60" | 72" |
| 1/2" | 180 | 150 | 125 | 106 | 93 | 86 |
| 3/4" | — | 290 | 255 | 215 | 197 | 173 |
| 1" | — | 581 | 512 | 442 | 397 | 347 |
| 1 1/4" | — | 1470 | 1200 | 1130 | 960 | 930 |

Maximum Capacity for Gas Flex Connectors in Thousands of Btuh **Liquified Petroleum** (0.5" WC Pressure Drop)

| Pipe Size | Length in Inches | | | | | |
|-----------|------------------|------|------|------|------|------|
| | 12" | 24" | 36" | 48" | 60" | 72" |
| 1/2" | 288 | 240 | 200 | 169 | 149 | 137 |
| 3/4" | — | 465 | 409 | 344 | 315 | 278 |
| 1" | — | 930 | 825 | 708 | 638 | 556 |
| 1 1/4" | — | 2352 | 1920 | 1808 | 1536 | 1488 |

** For reference only. Please consult gas pipe manufacturer for actual pipe capacities.